



School District of  
*Reedsburg*

Audit Presentation to the  
Board of Education

---

For the Year Ended  
June 30, 2009

---

Presented  
March 3, 2010

---

*Prepared by:*  
*Vig & Associates, LLC*  
*Certified Public Accountants & Business Advisors*

# SCHOOL DISTRICT OF REEDSBURG

## AUDIT OVERVIEW

- We have completed our audit of the School District of Reedsburg for the year ended June 30, 2009, and have issued an unqualified opinion on the financial statements of the District. Our report and the audited financial statements are presented in a bound document.
  
- The scope of our audit included all funds and activities of the District.
  
- Management has reviewed and accepted the financial statements and adjusting journal entries.
  
- A separate audit communications document designed for the Board of Education and key management has been submitted and should be read in conjunction with the audited financial statements.

# SCHOOL DISTRICT OF REEDSBURG

## FINANCIAL OBSERVATIONS FOR YEAR ENDED JUNE 30, 2009

- Fund Balance in the General Fund increased by \$121,639 over the prior year. End of the year fund balance totaled \$2,464,609, which represents just over one month of expenditures.
  
- Special Education Fund required a General Fund transfer of \$2,779,523 compared to \$2,809,032 in the prior year. \$2,988,186 was budgeted for this transfer.
  
- The Food Service Fund required a transfer from General Fund in the amount of \$69,088 compared to \$145,936 in the prior year. There was no budgeted amount for this transfer.
  
- The District recognized \$3,710,870 of expenditures financed with federal funding sources, and \$14,462,320 of expenditures from state funding sources.

# SCHOOL DISTRICT OF REEDSBURG

## STATEMENT OF REVENUES, EXPENDITURES AND CHANGES IN FUND BALANCES – GOVERNMENTAL FUNDS

	General Fund	Special Education Fund	Debt Service Fund	Nonmajor Gov't. Funds	2009 Total Gov't. Funds	2008 Totals (Memorandum Only)
<b>Revenues:</b>						
Property taxes	\$9,473,137	\$ -	\$1,817,807	\$ 93,710	\$11,384,654	\$ 10,655,081
Other local sources	305,062	-	23,120	770,089	1,098,271	1,086,553
Interdistrict sources	227,329	37,442	-	-	264,771	227,121
Intermediate sources	-	65,943	-	-	65,943	19,358
State sources	13,450,083	988,081	-	24,156	14,462,320	15,968,288
Federal sources	2,518,145	709,090	-	483,635	3,710,870	1,505,706
Other sources	58,953	-	-	497	59,450	155,463
<b>Total revenues</b>	<u>26,032,709</u>	<u>1,800,556</u>	<u>1,840,927</u>	<u>1,372,087</u>	<u>31,046,279</u>	<u>29,617,570</u>
<b>Expenditures:</b>						
<b>Current:</b>						
<b>Instruction:</b>						
Regular instruction	11,431,426	-	-	-	11,431,426	11,096,397
Vocational instruction	958,754	-	-	-	958,754	904,655
Physical instruction	963,641	-	-	-	963,641	908,816
Special education instruction	-	3,479,503	-	-	3,479,503	3,199,825
Other instruction	492,414	-	-	-	492,414	485,718
<b>Total instruction</b>	<u>13,846,235</u>	<u>3,479,503</u>	<u>-</u>	<u>-</u>	<u>17,325,738</u>	<u>16,595,411</u>
<b>Support services:</b>						
Pupil services	643,935	603,722	-	-	1,247,657	1,208,323
Instructional staff services	1,217,156	134,522	-	-	1,351,678	1,267,567
General administration services	362,325	-	-	-	362,325	320,680
Building administration services	1,377,526	693	-	-	1,378,219	1,279,348
Business services	402,891	-	-	-	402,891	403,921
Operation and maintenance	2,821,381	-	-	-	2,821,381	3,077,155
Pupil transportation	807,804	65,558	-	-	873,362	919,206
Central services	89,763	-	-	-	89,763	243,524
Insurance	268,053	-	-	-	268,053	272,324
Community service	-	-	-	32,130	32,130	2,741
Other support services	345,629	34,806	-	42,400	422,835	380,868
Food service	-	-	-	1,297,224	1,297,224	1,353,755
<b>Total support services</b>	<u>8,336,463</u>	<u>839,301</u>	<u>-</u>	<u>1,371,754</u>	<u>10,547,518</u>	<u>10,729,412</u>
<b>Debt service:</b>						
Principal	70,068	-	1,235,000	-	1,305,068	1,072,095
Interest	54,929	-	620,858	-	675,787	641,834
Debt issue costs	-	-	-	-	-	114,968
<b>Total debt service</b>	<u>124,997</u>	<u>-</u>	<u>1,855,858</u>	<u>-</u>	<u>1,980,855</u>	<u>1,828,897</u>
<b>Nonprogram:</b>						
Purchased instructional service	435,234	176,443	-	-	611,677	547,806
<b>Total nonprogram</b>	<u>435,234</u>	<u>176,443</u>	<u>-</u>	<u>-</u>	<u>611,677</u>	<u>547,806</u>
<b>Capital outlay</b>	<u>337,212</u>	<u>84,832</u>	<u>-</u>	<u>41,198</u>	<u>463,242</u>	<u>275,428</u>
<b>Total expenditures</b>	<u>23,080,141</u>	<u>4,580,079</u>	<u>1,855,858</u>	<u>1,412,952</u>	<u>30,929,030</u>	<u>29,976,954</u>
<b>Excess (deficiency) of revenues over expenditures</b>	<u>2,952,568</u>	<u>(2,779,523)</u>	<u>(14,931)</u>	<u>(40,865)</u>	<u>117,249</u>	<u>(359,384)</u>
<b>Other financing sources (uses):</b>						
Proceeds from refinancing debt	-	-	-	-	-	7,421,631
Proceeds from sale of assets	55,736	-	-	-	55,736	-
Principal payment of refinanced debt	-	-	-	-	-	(7,446,631)
Transfer from other funds	-	2,779,523	38,054	69,088	2,886,665	3,025,697
Transfer to other funds	(2,886,665)	-	-	-	(2,886,665)	(3,025,697)
<b>Total other financing sources (uses)</b>	<u>(2,830,929)</u>	<u>2,779,523</u>	<u>38,054</u>	<u>69,088</u>	<u>55,736</u>	<u>(25,000)</u>
<b>Net change in fund balances</b>	<u>121,639</u>	<u>-</u>	<u>23,123</u>	<u>28,223</u>	<u>172,985</u>	<u>(384,384)</u>
<b>Fund balance - beginning of year</b>	<u>2,342,970</u>	<u>-</u>	<u>841,199</u>	<u>64,607</u>	<u>3,248,776</u>	<u>3,633,160</u>
<b>Fund balance - end of year</b>	<u>\$ 2,464,609</u>	<u>\$ -</u>	<u>\$ 864,322</u>	<u>\$ 92,830</u>	<u>\$ 3,421,761</u>	<u>\$ 3,248,776</u>

# SCHOOL DISTRICT OF REEDSBURG

## STATEMENT OF REVENUES, EXPENDITURES AND CHANGES IN FUND BALANCES – BUDGET VS. ACTUAL – GENERAL FUND

	2009			Variance with Final Budget Favorable (Unfavorable)	2008 Actual Totals (Memorandum Only)
	Budgeted Amounts		Actual		
	Original	Final			
<b>Revenues:</b>					
Property taxes	\$ 9,473,137	\$ 9,473,137	\$ 9,473,137	\$ -	\$ 8,754,410
Other local sources	292,929	292,929	305,062	12,133	283,351
Interdistrict sources	278,168	278,168	227,329	(50,839)	209,100
State sources	15,130,662	15,130,662	13,450,083	(1,680,579)	15,091,836
Federal sources	775,678	775,678	2,518,145	1,742,467	605,702
Other sources	121,809	121,809	58,953	(62,856)	155,455
<b>Total revenues</b>	<b>26,072,383</b>	<b>26,072,383</b>	<b>26,032,709</b>	<b>(39,674)</b>	<b>25,099,854</b>
<b>Expenditures:</b>					
<b>Current:</b>					
<b>Instruction:</b>					
Regular instruction	11,588,922	11,588,922	11,431,426	157,496	11,096,397
Vocational instruction	949,538	949,538	958,754	(9,216)	904,655
Physical instruction	924,311	924,311	963,641	(39,330)	908,816
Other instruction	468,915	468,915	492,414	(23,499)	485,055
<b>Total instruction</b>	<b>13,931,686</b>	<b>13,931,686</b>	<b>13,846,235</b>	<b>85,451</b>	<b>13,394,923</b>
<b>Support services:</b>					
Pupil services	798,503	798,503	643,935	154,568	705,241
Instructional staff services	1,106,883	1,106,883	1,217,156	(110,273)	1,137,539
General administration services	322,692	322,692	362,325	(39,633)	320,680
Building administration services	1,289,015	1,289,015	1,377,526	(88,511)	1,274,948
Business services	391,124	391,124	402,891	(11,767)	403,921
Operation and maintenance	2,759,485	2,759,485	2,821,381	(61,896)	3,032,620
Pupil transportation	837,436	837,436	807,804	29,632	843,019
Central services	118,100	118,100	89,763	28,337	230,037
Insurance	263,975	263,975	268,053	(4,078)	272,324
Other support services	374,330	374,330	345,629	28,701	305,703
<b>Total support services</b>	<b>8,261,543</b>	<b>8,261,543</b>	<b>8,336,463</b>	<b>(74,920)</b>	<b>8,526,032</b>
<b>Debt service:</b>					
Principal	58,000	58,000	70,068	(12,068)	67,095
Interest	40,000	40,000	54,929	(14,929)	40,654
<b>Total debt service</b>	<b>98,000</b>	<b>98,000</b>	<b>124,997</b>	<b>(26,997)</b>	<b>107,749</b>
<b>Nonprogram:</b>					
Purchased instructional service	476,506	476,506	435,234	41,272	380,205
<b>Total nonprogram</b>	<b>476,506</b>	<b>476,506</b>	<b>435,234</b>	<b>41,272</b>	<b>380,205</b>
<b>Capital outlay</b>	<b>399,834</b>	<b>399,834</b>	<b>337,212</b>	<b>62,622</b>	<b>260,365</b>
<b>Total expenditures</b>	<b>23,167,569</b>	<b>23,167,569</b>	<b>23,080,141</b>	<b>87,428</b>	<b>22,669,274</b>
<b>Excess (deficiency) of revenues over expenditures</b>	<b>2,904,814</b>	<b>2,904,814</b>	<b>2,952,568</b>	<b>47,754</b>	<b>2,430,580</b>
<b>Other financing sources (uses):</b>					
Proceeds from sale of assets	56,400	56,400	55,736	(664)	-
Transfer to other funds	(3,026,241)	(3,026,241)	(2,886,665)	139,576	(3,025,697)
<b>Total other financing sources (uses)</b>	<b>(2,969,841)</b>	<b>(2,969,841)</b>	<b>(2,830,929)</b>	<b>138,912</b>	<b>(3,025,697)</b>
<b>Net change in fund balances</b>	<b>(65,027)</b>	<b>(65,027)</b>	<b>121,639</b>	<b>186,666</b>	<b>(595,117)</b>
<b>Fund balance - beginning of year</b>	<b>2,342,970</b>	<b>2,342,970</b>	<b>2,342,970</b>	<b>-</b>	<b>2,938,087</b>
<b>Fund balance - end of year</b>	<b>\$ 2,277,943</b>	<b>\$ 2,277,943</b>	<b>\$ 2,464,609</b>	<b>\$ 186,666</b>	<b>\$ 2,342,970</b>

# SCHOOL DISTRICT OF REEDSBURG

## STATEMENT OF REVENUES, EXPENDITURES AND CHANGES IN FUND BALANCES – BUDGET VS. ACTUAL – SPECIAL EDUCATION FUND

	2009		Actual	Variance with Final Budget Favorable (Unfavorable)	2008 Actual Totals (Memorandum Only)
	Budgeted Amounts				
	Original	Final			
<b>Revenues:</b>					
Interdistrict sources	\$ 15,876	\$ 15,876	\$ 37,442	\$ 21,566	\$ 18,021
Intermediate sources	33,633	33,633	65,943	32,310	19,358
State sources	813,854	813,854	988,081	174,227	852,914
Federal sources	507,631	507,631	709,090	201,459	447,018
<b>Total revenues</b>	<b>1,370,994</b>	<b>1,370,994</b>	<b>1,800,556</b>	<b>429,562</b>	<b>1,337,311</b>
<b>Expenditures:</b>					
<b>Current:</b>					
<b>Instruction:</b>					
Special education instruction	3,273,014	3,273,014	3,479,503	(206,489)	3,199,825
Other instruction	-	-	-	-	663
<b>Total instruction</b>	<b>3,273,014</b>	<b>3,273,014</b>	<b>3,479,503</b>	<b>(206,489)</b>	<b>3,200,488</b>
<b>Support services:</b>					
Pupil services	531,110	531,110	603,722	(72,612)	503,082
Instructional staff services	143,596	143,596	134,522	9,074	129,799
Building administration services	250	250	693	(443)	4,400
Operation and maintenance	-	-	-	-	44,535
Pupil transportation	62,820	62,820	65,558	(2,738)	76,187
Central services	-	-	-	-	13,487
Other support services	39,061	39,061	34,806	4,255	-
<b>Total support services</b>	<b>776,837</b>	<b>776,837</b>	<b>839,301</b>	<b>(62,464)</b>	<b>771,490</b>
<b>Nonprogram:</b>					
Purchased instructional service	200,706	200,706	176,443	24,263	167,601
<b>Total nonprogram</b>	<b>200,706</b>	<b>200,706</b>	<b>176,443</b>	<b>24,263</b>	<b>167,601</b>
<b>Capital outlay</b>	<b>108,623</b>	<b>108,623</b>	<b>84,832</b>	<b>23,791</b>	<b>6,764</b>
<b>Total expenditures</b>	<b>4,359,180</b>	<b>4,359,180</b>	<b>4,580,079</b>	<b>(220,899)</b>	<b>4,146,343</b>
<b>Excess (deficiency) of revenues over expenditures</b>	<b>(2,988,186)</b>	<b>(2,988,186)</b>	<b>(2,779,523)</b>	<b>208,663</b>	<b>(2,809,032)</b>
<b>Other financing sources (uses):</b>					
Transfer from General Fund	2,988,186	2,988,186	2,779,523	(208,663)	2,809,032
<b>Total other financing sources (uses)</b>	<b>2,988,186</b>	<b>2,988,186</b>	<b>2,779,523</b>	<b>(208,663)</b>	<b>2,809,032</b>
<b>Net change in fund balances</b>	<b>-</b>	<b>-</b>	<b>-</b>	<b>-</b>	<b>-</b>
<b>Fund balance - beginning of year</b>	<b>-</b>	<b>-</b>	<b>-</b>	<b>-</b>	<b>-</b>
<b>Fund balance - end of year</b>	<b>\$ -</b>	<b>\$ -</b>	<b>\$ -</b>	<b>\$ -</b>	<b>\$ -</b>

# SCHOOL DISTRICT OF REEDSBURG

## GOVERNMENTAL FUNDS 2008 - 2009 REVENUES

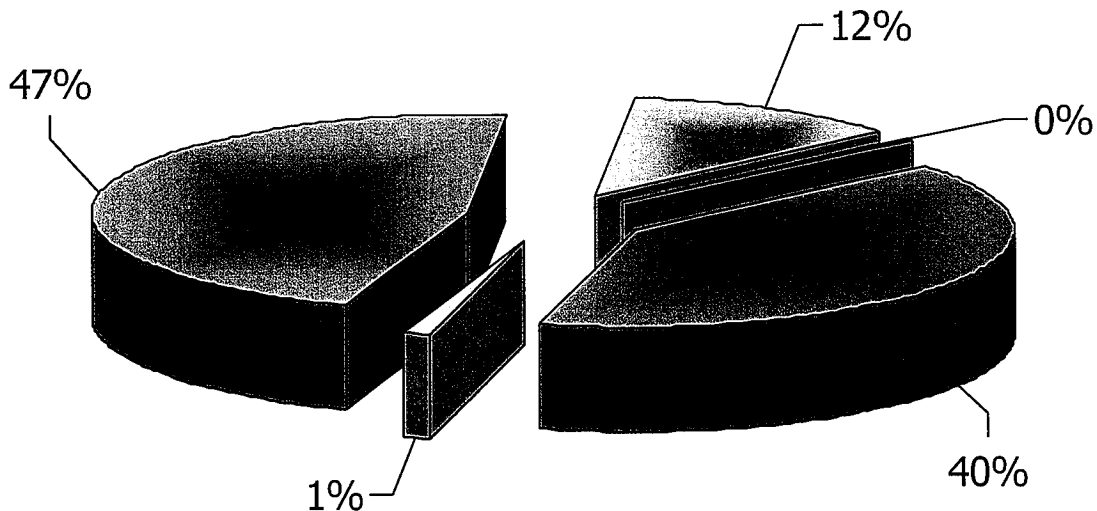

- Property Taxes & Other Local Sources (\$12,482,925)
- Interdistrict & Intermediate Sources (\$330,714)
- State Sources (\$14,462,320)
- Federal Sources (\$3,710,870)
- Other Revenues (\$59,450)

### OBSERVATIONS AND COMMENTS:

- The most significant revenue from local sources is property taxes totaling \$11,384,654. Property tax revenue is controlled by state revenue limits, and is apportioned to the general, debt service, and community service funds.
- The most significant revenue from state sources is equalization aid totaling \$12,598,016.

SOURCE: EXTRACTED FROM EXHIBIT IV – 6/30/09 AUDITED FINANCIAL STATEMENTS

# SCHOOL DISTRICT OF REEDSBURG

## GOVERNMENTAL FUNDS 2008 - 2009 EXPENDITURES

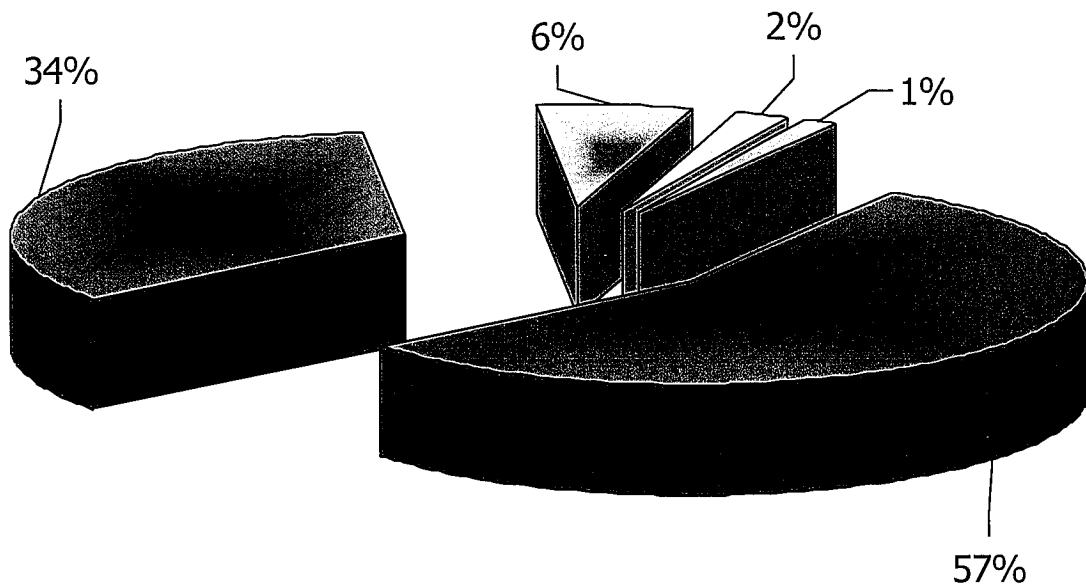

- Instruction Expenditures (\$17,325,738)
- Support Services Expenditures (\$10,547,518)
- Debt Service (\$1,980,855)
- Nonprogram (\$611,677)
- Capital Outlay (\$463,242)

SOURCE: EXTRACTED FROM EXHIBIT IV – 6/30/09 AUDITED FINANCIAL STATEMENTS

# SCHOOL DISTRICT OF REEDSBURG

## CHANGES IN LONG-TERM OBLIGATIONS

➤ Long-term obligations of the District are as follows:

	Balance 07/01/2008	Increases	Decreases	Balance 06/30/2009	Amounts Due Within One Year
Bonds, notes and loans payable:					
General obligation debt	\$ 16,111,631	\$ -	\$ 1,235,000	\$ 14,876,631	\$ 1,335,000
Total bonds, notes and loans payable	16,111,631	-	1,235,000	14,876,631	1,335,000
Other liabilities:					
Capital leases	150,047	-	70,068	79,979	73,214
Vested compensated absences	94,919	3,220	1,710	96,429	96,429
Other post-employment benefits	-	1,479,915	299,189	1,180,726	-
Total other liabilities	244,966	1,483,135	370,967	1,357,134	169,643
Total long-term liabilities	\$ 16,356,597	\$ 1,483,135	\$ 1,605,967	\$ 16,233,765	\$ 1,504,643

➤ The 2009 equalized valuation of the District as certified by the Wisconsin Department of Revenue is \$1,435,675,983. The legal debt limit and margin of indebtedness as of June 30, 2009 is as follows:

Debt limit (10% of \$1,435,675,983)	\$ 143,567,598
Deduct long-term debt applicable to debt margin	14,876,631
Margin of indebtedness	<u>\$ 128,690,967</u>
Debt capacity remaining	89.6%

# SCHOOL DISTRICT OF REEDSBURG

## ENROLLMENT TREND – FULL-TIME EQUIVALENT

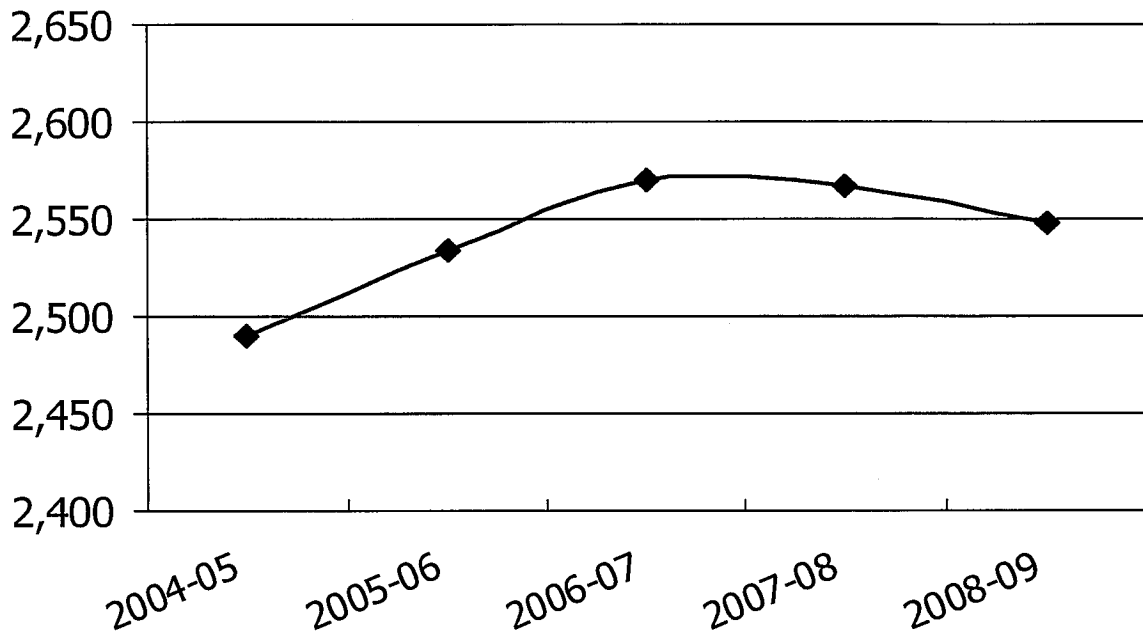

### Enrollment Trends

#### (September & Summer FTE Membership Averages)

2004 - 05	-	2,490
2005 - 06	-	2,534
2006 - 07	-	2,570
2007 - 08	-	2,567
2008 - 09	-	2,548

#### OBSERVATIONS AND COMMENTS:

- Enrollment totals directly affect equalization aid revenue.

# SCHOOL DISTRICT OF REEDSBURG

## APPORTIONMENT OF TAXES

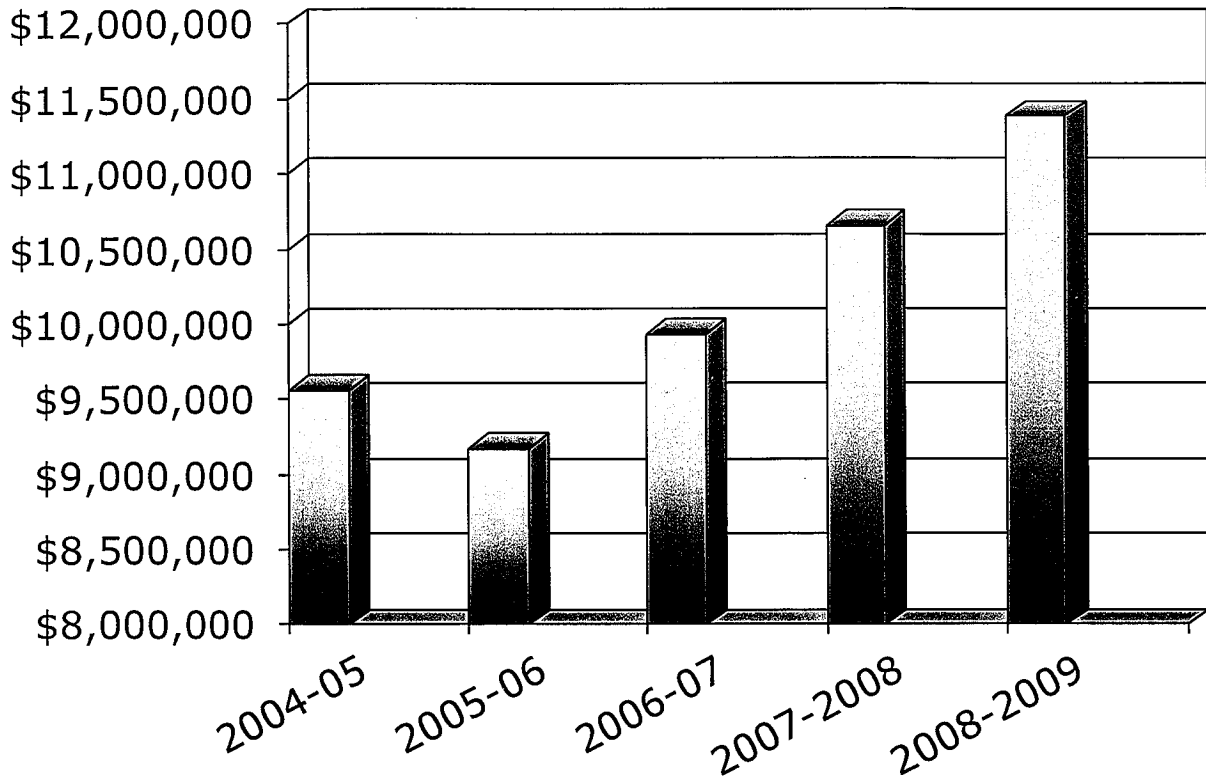

### Apportionment of Taxes

2004 - 2005	\$ 9,561,927
2005 - 2006	\$ 9,169,212
2006 - 2007	\$ 9,936,493
2007 - 2008	\$ 10,655,081
2008 - 2009	\$ 11,384,654

### OBSERVATIONS AND COMMENTS:

- Equalization aid, student enrollment and revenue limit formula imposed by statute directly impacts the District's tax levy.

# SCHOOL DISTRICT OF REEDSBURG

## EQUALIZATION AID

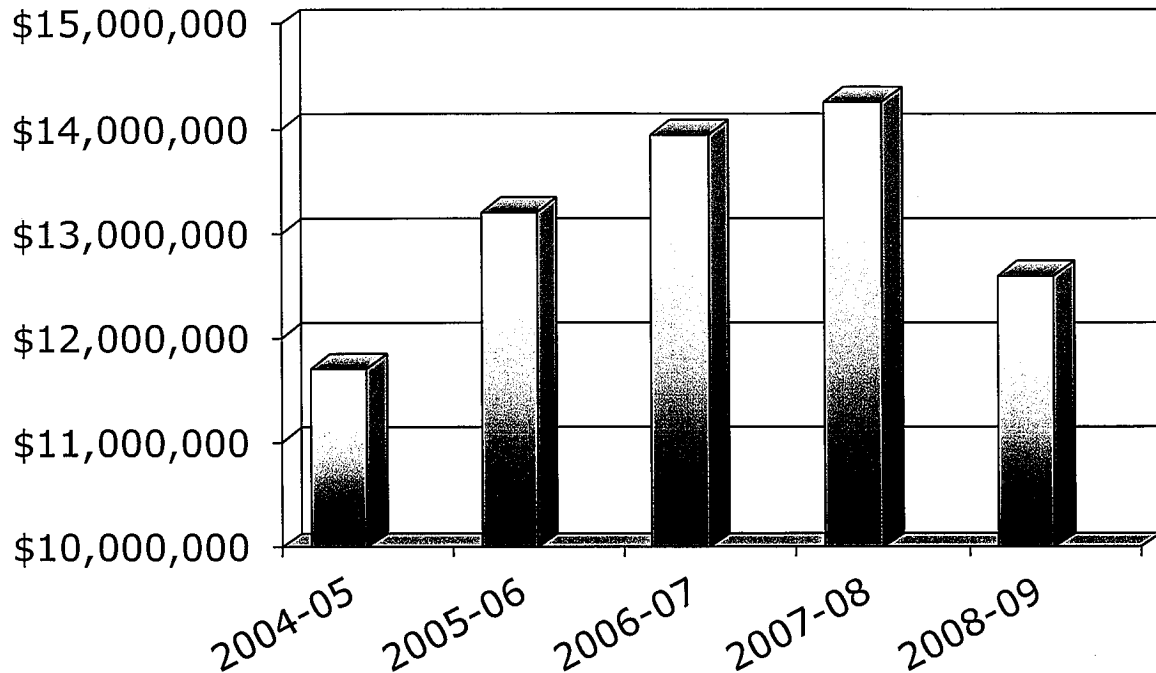

### Equalization Aid

2004 - 2005	\$ 11,701,474
2005 - 2006	\$ 13,207,195
2006 - 2007	\$ 13,944,925
2007 - 2008	\$ 14,250,600
2008 - 2009	\$ 12,598,016*

\* ARRA – State Fiscal Stabilization Fund amount excluded - \$1,619,751

### OBSERVATIONS AND COMMENTS:

➤ Equalization aid is an averaging process of enrollment over the last three years and is determined by a formula authorized by state statute.

# SCHOOL DISTRICT OF REEDSBURG

## TREND IN GENERAL FUND BALANCE

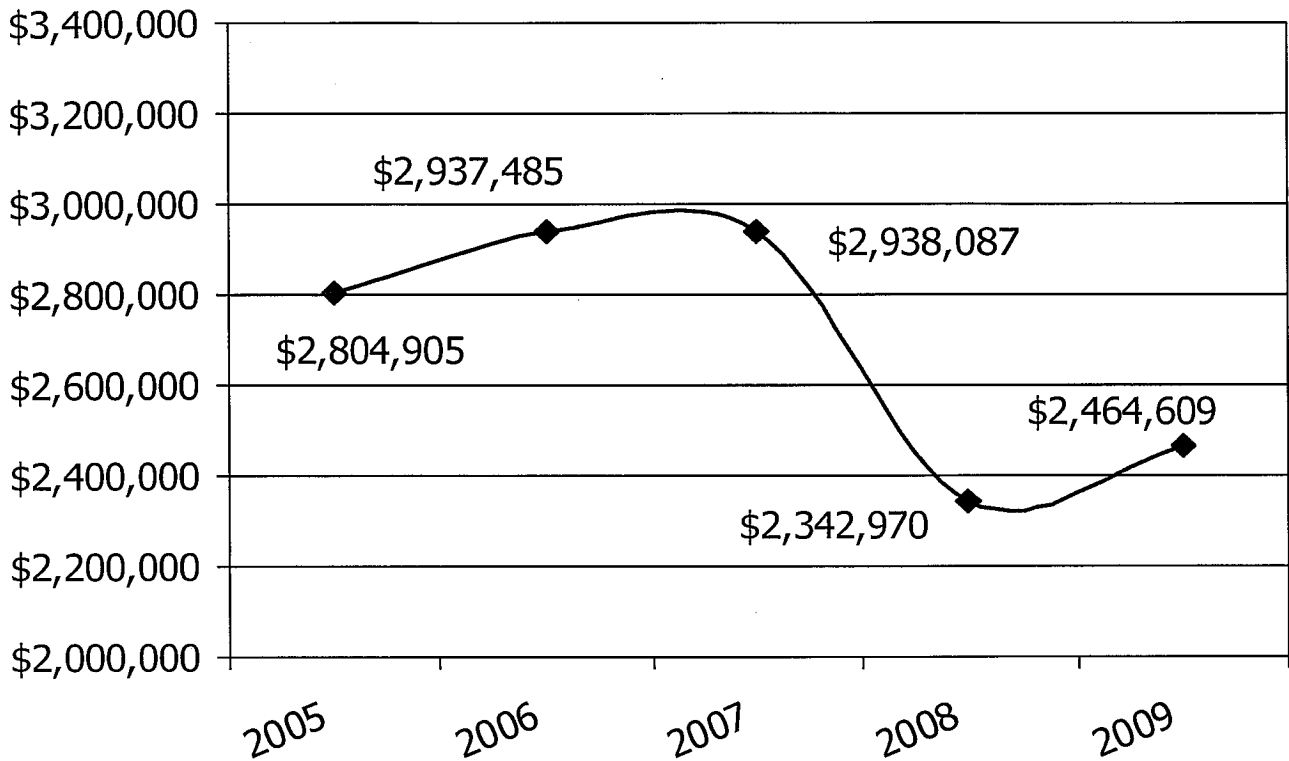

### General Fund Balances as of June 30 Year End



**WISCONSIN DEPARTMENT OF PUBLIC INSTRUCTION**  
**SCHOOL FINANCE DATA WAREHOUSE**

## Reedsburg School District FY 2007-2008 Comparative Cost per Member

FY 2007-2008 Reedsburg School District  
 Comparative Cost per Member

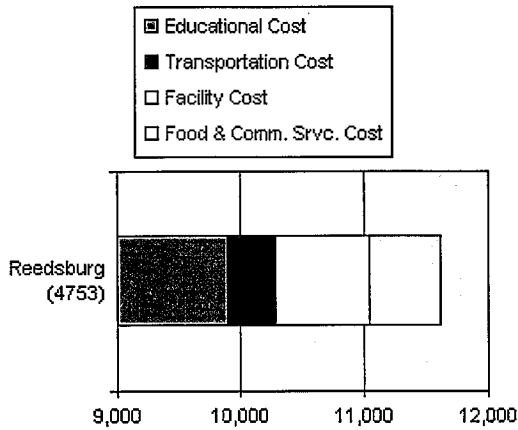

[Return to choose another Standard Report.](#)

[Show Data in Excel Format](#)

### FY 2007-2008 Comparative Cost per Member for Reedsburg School District

School District	Educational Cost Per Member		Transportation Cost Per Member		Facility Cost Per Member		Total Educational Cost Per Member		Food & Comm. Service Cost Per Member		Total District Cost Per Member		Membership	
	Amount	Rank	Amount	Rank	Amount	Rank	Amount	Rank	Amount	Rank	Amount	Rank	Amount	Rank
Reedsburg (4753)	\$9,895	213	\$383	99	\$769	173	\$11,047	164	\$561	325	\$11,608	181	2,553	343
<b>State Average</b>	\$10,220		\$543		\$902		\$11,665		\$490		\$12,155		2,030	

[Return to choose another Standard Report.](#)

Questions about this page should be directed to [dpifin@dpi.state.wi.us](mailto:dpifin@dpi.state.wi.us).

[DEPARTMENT HOMEPAGE](#) | 
 [SEARCH & INDEX](#) | 
 [SFS HOMEPAGE](#)

Copyright: State of Wisconsin Department of Public Instruction  
 Phone: 1-800-441-4563 (U.S. only) / 608-266-3390